

RISA

Underground and Overhead Networks & Infrastructures.

risa.fr



AERIAL

G2T

SUBFRAME AND STABILISATION

Box-type subframe with turret mounting plate and 2 rear A-frame stabilisers
 Front post holder and crane support, rear post holder
 Hydraulic pump with fixed flow rate
 Hydraulic cooler with automatic engagement by thermostatic probe
 Plateau in reinforced sheet metal
 Emergency stops on R and L sides

G2T DRILLING CRANE

Lifting 2 m.t to 5 m on one strand
 Lifting 4 m.t to 2.50 m with a block (optional)
 Kinematics with 1 articulated arm and 1 telescope
 Lifting winch with load-holding valve: 2 t in 1st layer, high and low limit switches
 Height under hook of 8 m
 Maximum horizontal reach: 6.15 m
 Drilling distance: 3.10 m to 5.80 m
 Lifting range at full load on 125° AR (depending on mounting)
 Reduced lifting range on 235° FWD with electronic limiter (depending on mounting)
 LEDs for display of lifting rates (90%, 100%, 110%)
 Continuous and unlimited rotation by crown wheel with internal gearing, geared motor Ø 825 mm
 Drill motor, torque 1,000 m/kg, R and L rotation, hex drive of Ø 70 mm
 Auger support device on the 1st telescope
 Radio control of crane and outriggers, remote stop and start and 2 speed control screen
 Automatic acceleration of the engine for each movement
 Electronic load limiter

Capacity according to stabilisation

* According to model



G2T equipped with a Down-the-hole Hammer (DTH)



825mm sprocket with internal teeth



Auger unlocking

- Front right / left and rear access
- Auger support



Radio control of the crane and stabilizers



MAIN OPTIONS

- 825mm sprocket with internal teeth
- Right and left front access
- Auger support
- Capacity according to stabilisation
- Auger unlocking
- Armoured sheet metal decking
- Radio control
- Spare wheel
- Electrically operated trifold cabin protection 2 flashing lights
- Extendable stakes
- 300mm diameter auger support
- 150 litre hydraulic tank
- Auger support Retractable rear post holder
- Rear access and stabiliser control
- Tool intake 30 litres per minute - 140 bar
- Chock basket
- Rear lights with approved protection
- Led position light
- Folding step
- Cone holder



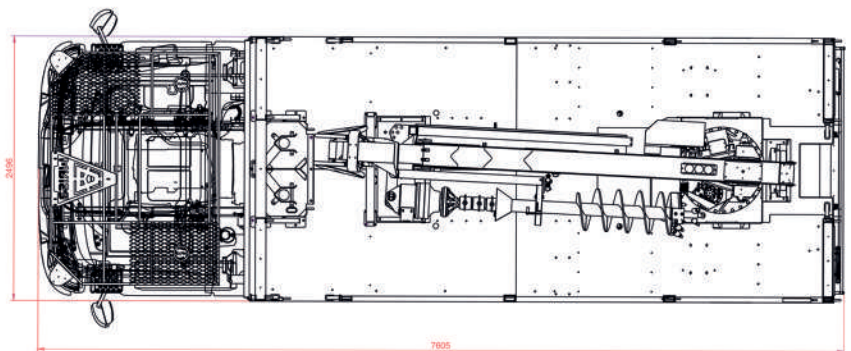
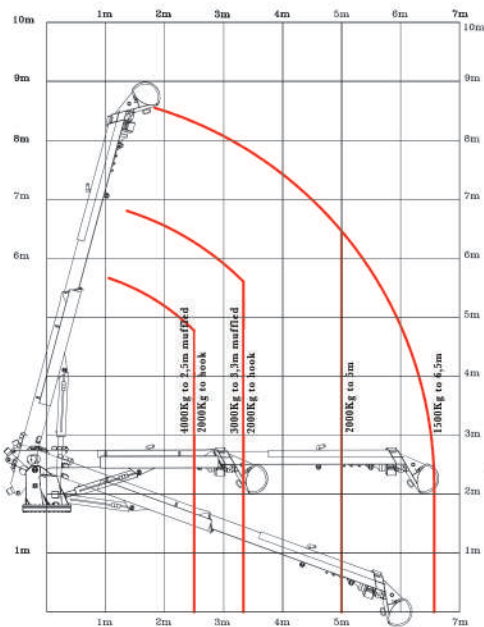
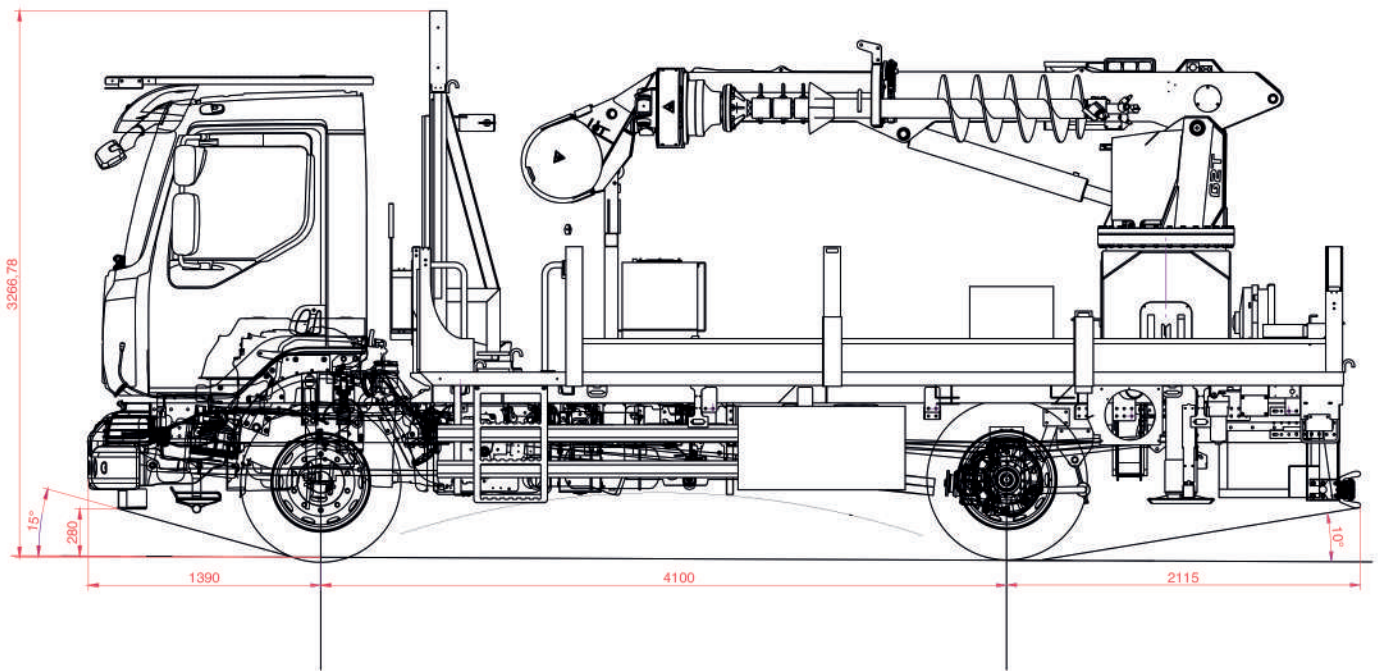

G2T Drilling crane

risa.fr

RISA

67 Avenue Edouard Herriot
82303 CAUSSADE
FRANCE.

Phone. 05 63 65 17 83

